

Guidelines for Handling, Installation and Maintenance of Wire Ropes

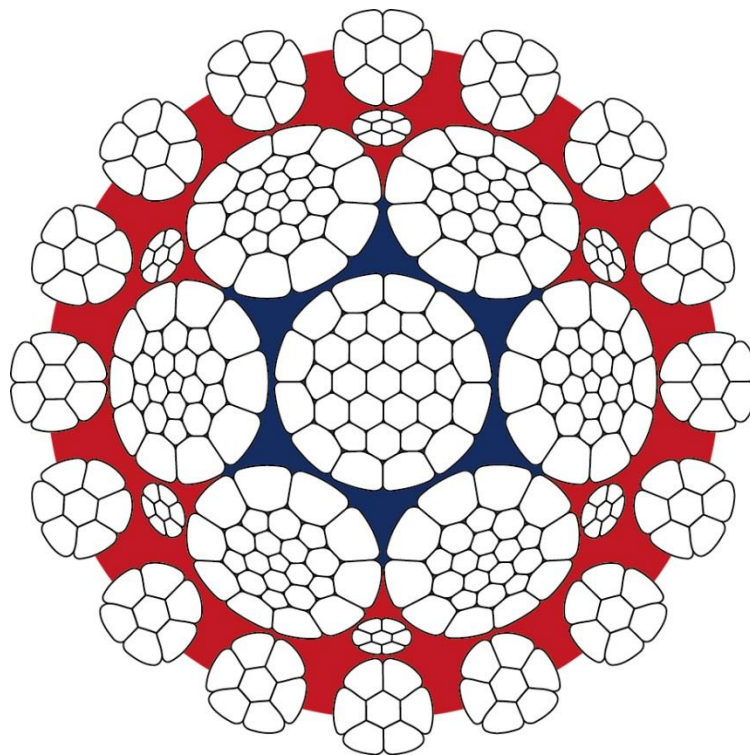

COPYRIGHT

CASAR Drahtseilwerk Saar GmbH reserves all rights for these guidelines. In particular, we claim copyright and competition law protection for this.

It is only permitted to change or copy these guidelines or parts of them with our express prior consent.

These technical documents or parts of them may not be duplicated, distributed, made available to third parties or used in an unauthorised way for competitive purposes without our prior consent.

Limbach, 23/11/2022

Board of Management
WIRECO Germany GmbH
Casarstraße 1, 66459 Kirkel-Limbach
Germany

EC DECLARATION OF CONFORMITY

Complies with the Directive on Machinery 2006/42/EC in the valid version

We, Casar Drahtseilwerk Saar GmbH, hereby declare under our sole authority that the machine described in the following meets all relevant requirements of the EU Directive on Machinery 2006/42/EC. It is also confirmed that the delivery was checked and complies with the agreements made during order acceptance.

The following harmonised standards were used:

EN ISO 12100 Safety of machinery – General design principles – Risk assessment and risk reduction

EN 12385-1: 2002+A1: 2008 Steel wire ropes - Safety - Part 1: General requirements

EN 12385-2: 2002+A1: 2008 Steel wire ropes - Safety - Part 2: Terms, designation and classification

EN 12385-3: 2004+A1: 2008 Steel wire ropes - Safety - Part 3: Information for use and maintenance

EN 12385-4: 2002+A1: 2008 Steel wire ropes - Safety - Part 4: Stranded ropes for general lifting purposes

EN 12385-10: 2003+A1: 2008 Steel wire ropes - Safety - Part 10: Spiral ropes for general structural applications

EN 13411-4: 2011-06 End connections for steel wire ropes - Safety - Part 4: Cast with metal and plastic

The following other standards and specifications were used:

EN10264-1: 2012-3 Steel wire and wire products - Steel wire for ropes - Part 1: General requirements

EN10264-2: 2012-3 Steel wire and wire products - Steel wire for ropes - Part 2: Cold-drawn non-alloy steel wire for ropes for general applications.

Changes to the machine as well as non-observance of the regulations from EN 12385-3

“Steel wire rope – Safety; Part 3: Information for use and maintenance” as well as ISO 4309

“Cranes - Wire ropes - Care, maintenance, installation, examination and discard” will void the validity of this declaration.

Limbach, 23/11/2022

Board of Management
WIRECO Germany GmbH
Casarstraße 1, 66459 Kirkel-Limbach
Germany

INSTALLATION DECLARATION

Installation declaration according to EC Directive on Machinery 2006/42/EC / Annex IIB)

We hereby declare that the "incomplete machine", as far as possible in the scope of delivery, complies with the basic requirements of the

Directive on Machinery (2006/42/EC)

EMC – Guidelines (2004/108/EC).

Commissioning of the incomplete machine is not permitted until it has been installed in a machine and this complies with regulations of the EC Directive on Machinery and the EC declaration of conformity according to annex II A.

The associated directive includes important technical safety information and regulations for the installation, commissioning, maintenance and servicing of the product.

Special technical documents according to Annex VII Part B were issued for the product. These documents can be sent by post or email to a national authority following a reasoned request.

Information: If the product is modified without agreement from the manufacturer, this declaration shall cease to apply.

Limbach, 23/11/2022

Board of Management
WIRECO Germany GmbH
Casarstraße 1, 66459 Kirkel-Limbach
Germany

CONTENTS

Copyright.....	2
EC declaration of conformity	3
Installation declaration	4
1. General.....	7
1.1 Preface	7
1.2 Intended use	8
1.3 Liability	9
2. Safety	10
2.1 Presentation of warning information	10
2.2 Presentation of danger levels.....	11
2.3 Safety symbols.....	12
2.4 Dangers resulting from non-observance of safety information	14
2.5 Safety information for the wire rope operator	14
2.6 Material-related health and safety information	15
2.7 Medical emergency measures	17
2.8 Information for an emergency	18
3. Specification of wire ropes	19
3.1 General	19
3.2 Components and manufacture of a wire rope/stranded rope.....	19
3.3 Direction of lay of the rope.....	23
3.4 Lay type of the rope	23
3.5 Choosing the correct direction of lay.....	25
3.6 Rotation-resistant and non-rotation-resistant ropes.....	26
3.7 Strength.....	27
3.8 Surface	27
3.9 Diameter and manufacturing tolerance	27
3.10 Wire rope length	28
3.11 The application temperature range of CASAR special wire ropes.....	28
4. Handling wire ropes	29
4.1 Transporting special wire ropes.....	29
4.2 Storing special wire ropes	29
5. Installation of steel wire ropes.....	30
5.1 Incorrect unwinding	30

5.2	Correctly unwinding a steel wire rope from the coil.....	30
5.3	Correctly unwinding a steel wire rope from the reel	31
5.4	Winding the rope from a reel to a drum	31
5.5	The fleet angle	32
5.6	The grooves of drums and sheaves	33
5.7	Installing the new rope	35
5.8	The preload.....	38
5.9	“Breaking in” the steel wire rope.....	39
5.10	Cutting steel wire ropes.....	39
6.	Maintaining steel wire ropes	41
6.1	Relubricating steel wire ropes	41
6.2	Cleaning wire ropes	43
6.3	Removing broken wires.....	43
7.	Discard criteria according to DIN ISO 4309	44
7.1	Visible wire breaks.....	44
7.2	Diameter reduction	47
7.3	Strand break.....	48
7.4	Corrosion	49
7.5	Deformation and other damage	50
	Bibliography/directory of applicable standards	53

1. GENERAL

These guidelines apply for wire ropes in terms of the Directive on Machinery 2006/42/EC of the manufacturer WIRECO Germany GmbH, registered at the Saarbrücken local court HRB 17125.

1.1 PREFACE

These guidelines are aimed at persons who directly or indirectly come into contact with wire ropes and should always be available to them.

They should ease the proper handling of wire ropes and convey the necessary expertise.

Compliance with the instructions in the guidelines should ensure the safe handling of wire ropes and help to prevent dangers and minimise repair costs and downtimes.

Our number one priority is user safety, which is best achieved by our joint efforts. We feel that you make a major contribution to safety if you:

1. Comply with employer, job site and governmental rules
2. Read, understand and follow the instructions in this and other manuals supplied with the wire ropes.
3. Use good safe work practices in a common-sense way
4. Only have trained/certified operators, directed by informed and knowledgeable supervision, handling installing and maintaining the wire ropes. If there is anything in this manual that is not clear or which you believe should be added, please contact us:

Internet: www.casar.de

Phone: +49 6841 / 8091 0

DANGER



Failure to obey the instructions and safety rules in this manual will result in death or serious injury.

IMPORTANT:

Wire ropes are used in a variety of different applications. For reasons of clarity, all detailed information cannot be provided and every conceivable operational case cannot be covered in these guidelines. In the event of problems, uncertainties or if further information is required, we ask you to contact WIRECO Germany GmbH ("manufacturer" in the following) directly.

1.2 INTENDED USE

Intended use

The Directive on Machinery 2006/42/EC, Art. 1e specifies what is considered intended use when using wire ropes. Normal use is considered to be its use for **lifting purposes, as part of lifting gear or load handling equipment.**

Any other use beyond this is excluded from the liability of the manufacturer as improper use.

Unauthorised changes

If unauthorised changes are made to the wire ropes, the manufacturer shall not be liable for any damage resulting from this.

If the wire ropes are incorrectly or improperly handled as well as if they are used by unauthorised or untrained personnel, there are serious dangers:

- Dangers that affect life and limb
- Dangers relating to the wire ropes themselves
- Dangers for assets of the user

If the wire ropes are used outside of Germany, the safety regulations of the country of use apply.

Regulations in the country of use

Not only these guidelines are authoritative. Together with them, national rules and regulations must be observed that apply at the deployment site, i.e. in the country of use. The binding regulations for accident prevention as well as the technical rules that are valid for safe and proper work are to be applied in particular.

Important: The emergency numbers applicable in the country of use must always be specified.

Limited load

The specified permitted loads of the wire ropes must be complied with due to reasons of safety and liability.

Observe the following: Further information can be found in the technical documentation of the machine manufacturer.

Use, maintenance, servicing

If regulations for operational, technical maintenance or servicing conditions are set on the part of the wire rope or machine manufacturer, these regulations for intended use must also be complied with.

1.3 LIABILITY

Liability cases

Due diligence obligations stated as part of the Directive on Machinery 2006/42/EC were complied with on the part of the manufacturer. Therefore, the manufacturer's liability is limited to damage to the rope that has occurred despite proper use. The contractual agreements are the basis for the guarantee.

Correction of faults

Defects that arise must only be corrected by persons trained for this and specially assigned to do so.

Limitations of liability

We assume no liability for safety defects that are not yet accounted for according to today's technical understanding. Furthermore, we assume no liability for the effects of

- Violations of safety information,
- Violations of information about special dangers,
- Violations of the ban on unauthorised design changes to the systems and devices.

In addition, as the manufacturer, we assume no liability for the use of our wire ropes in conjunction with faulty and non-compliant systems and devices.

2. SAFETY

2.1 PRESENTATION OF WARNING INFORMATION

Warning information is stated by us before all handling instructions with which residual risks can be associated. This information must always be observed and followed.

To indicate this, the warning information is clearly separated from other text and identified multiple times with

- 1) a **symbol**,
- 2) a **colour scheme** (for example, red stands for the highest danger level),
- 3) **signal words** such as 'Warning', 'Danger', 'Caution' or 'Attention' as well as
- 4) possible **text for explanations**.

As the symbols alone do not provide adequate safety information, it is important to read the complete text of the safety information.

In these **guidelines**, the differentiation of danger levels and presentation according to danger levels occurs as follows:

2.2 PRESENTATION OF DANGER LEVELS

Warnings for possible personal injury



DANGER

Highest danger level. Reference to an imminently dangerous situation that will cause death or serious injury if the safety regulations are not complied with.

WARNING



Warning information. Reference to an imminently dangerous situation that can cause death or serious injury if the safety regulations are not complied with.

CAUTION



Reference for care to be taken. Reference to a possibly dangerous situation that can cause property damage or slight to moderate injury if the safety regulations are not complied with.

Warnings for possible property damage

ATTENTION

Reference for compliance. Refers to possibly harmful situations that can cause damage to the product or its surroundings if not complied with.

2.3 SAFETY SYMBOLS

2.3.1 Prohibition symbols

The prohibition symbols used in these guidelines indicate when and/or which protective clothing is to be worn when working with wire ropes to prevent possible dangers for persons.



Attention! – General mandatory signs



Wear safety gloves – Protective gloves protect hands from friction, abrasion, piercing and deep cuts as well as contact with hot surfaces.



Wear a helmet – A helmet provides protection from falling and flying parts and materials.



Wear eye protection – Goggles protect eyes from flying parts and liquid splashes.



Wear safety shoes – Safety shoes protect feet from heavy falling parts and prevent slipping on slippery floors.



Wear protective clothing – Tight work clothing with a low tear strength, tight arms and without protruding parts is advised. Wear face protection!



Use face protection



Wear a mask!



Read the operating instructions!

2.3.2 Warning symbols

The warning symbols used in these guidelines indicate different dangers that can arise while using ropes. They indicate the type of possible risks.



Attention! – General warning of a hazardous area



Warning of risk of being pulled in



Warning of crushing

2.3.3 Prohibition sign



Prohibited! – Symbol for designating a general prohibition.

2.3.4 Rescue sign



First aid – Reference to first aid equipment.

2.4 DANGERS RESULTING FROM NON-OBSERVANCE OF SAFETY INFORMATION

CAUTION



The wire ropes described in the guidelines are manufactured according to DIN EN 12385-1:2002+A1:2008. This means: They correspond to the current state of technology with regard to their operational safety and construction. They are protected against dangers according to the Directive on Machinery 2006/42/EC.



Danger information: To prevent dangers arising when handling wire ropes, the personnel involved must be trained, the ropes should be properly handled used for their intended purpose.

2.5 SAFETY INFORMATION FOR THE WIRE ROPE OPERATOR

CAUTION

Knowledge of safety regulations



The entire team of persons who are involved with the use of wire ropes – from the workers to the supervisors – must be familiar with the safety regulations from this chapter (chapter 2). The guidelines must be available at the installation site for direct inspection. All safety information must be followed. The required protective clothing/equipment must be provided and used. The wire ropes may only be operated when in a perfect condition.

Special information about the topic of withdrawal from service can be found on page 42/43.

INFORMATION

Proper employee training relevant to safety



Specific training is used to prevent accidents and downtimes: It is important that user companies train their employees to properly work with wire ropes in a focused, comprehensive and verifiable manner. The competences in the team for maintenance, servicing and cleaning should also be clearly assigned. Also ensure proper training for relevant work here.

2.6 MATERIAL-RELATED HEALTH AND SAFETY INFORMATION

2.6.1 General

The materials for the manufacture of wire ropes are not harmful to health at the time of their delivery. They are made of non-harmful, unalloyed steel wire, steel wire with a coating, wire ropes with plastic sheath or non-rusting steel wire. Harmful substances can therefore only arise or come into being during further processing.

CAUTION



Important information: Only persons who are familiar with the handling of wire ropes and who are assigned to do so may use wire ropes during work.

2.6.2 Dust and vapours – possible dangers during further processing

CAUTION

Dust and vapours that arise during further processing due to cutting, annealed cutting, grinding and cleaning ropes can be a hazard to the health of the persons involved.



An acute health hazard can arise during improper handling of fibre cores made of natural or synthetic fibres, rope lubricants, possible fillers as well as sheaths.

Vapours that are a hazard to respiration can arise when cutting ropes using cutting discs or during annealed cutting.

Always ensure appropriate safety equipment – especially during work that is a hazard to the eyes. During cutting and annealed cutting, wear tight-fitting clothing, eye protection, safety gloves and safety shoes



2.6.3 Proper handling of lubricants

CAUTION



Precautionary measures when using lubricants:

- Different lubricants are used to protect wire ropes. **Prevent skin contact** with these lubricants! The following points generally apply: Clean your hands after they come into contact with wire ropes and, if necessary, apply skin protection cream.
- Make sure protective gloves do not let through lubricants.
- Wear protective clothing to prevent unnecessary contact.
- Make use of first aid treatment even for the most minor injuries.



Avoid the following at all costs:



- Put cloths or tools contaminated with lubricant in pockets.
- Use dirty cloths for wiping off lubricants from the skin.
- Wear clothing contaminated with lubricants.
- Use solvent such as paraffin or gasoline to remove lubricants from the skin.

2.6.4 Other rope components

CAUTION



Even if lubricants, natural fibres, synthetic fibres and synthetic fillers as well as sheaths in a solid form are not flammable or explosive, they can still support fires in conjunction with other substances. The required fire protection is therefore to be ensured on the part of the user.

2.7 MEDICAL EMERGENCY MEASURES

INFORMATION

For inhalation of hazardous materials: Take the person concerned into the fresh air and get medical help.



For skin contact: Clean the areas of skin with soap and water.

For contact with the eyes: Rinse out the harmful substances intensively under running water. Seek medical help.

If rope components are swallowed: Get direct medical help.

2.8 INFORMATION FOR AN EMERGENCY

1. Report accident: call 112

- Who reports the accident?
- What happened?
- Where is the place of injury?
- How many persons are injured?
- Wait for queries.

2. Provide first aid.



- Secure the accident site to prevent consequential injury
- Take any injured persons out of the danger zone
- Look after injured persons

3. Initiate further measures.

- Alert first aid helper/emergency response officer
- Alternatively: Emergency doctor, tel. 112
 Fire department, tel. 112
- Different local emergency numbers are to be added by the user and must be clearly visible.

3. SPECIFICATION OF WIRE ROPES

3.1 GENERAL

A rope is an elongated, flexible, elastic element made of twisted fibres or wires for transferring tensile forces.

3.2 COMPONENTS AND MANUFACTURE OF A WIRE ROPE/STRANDED ROPE

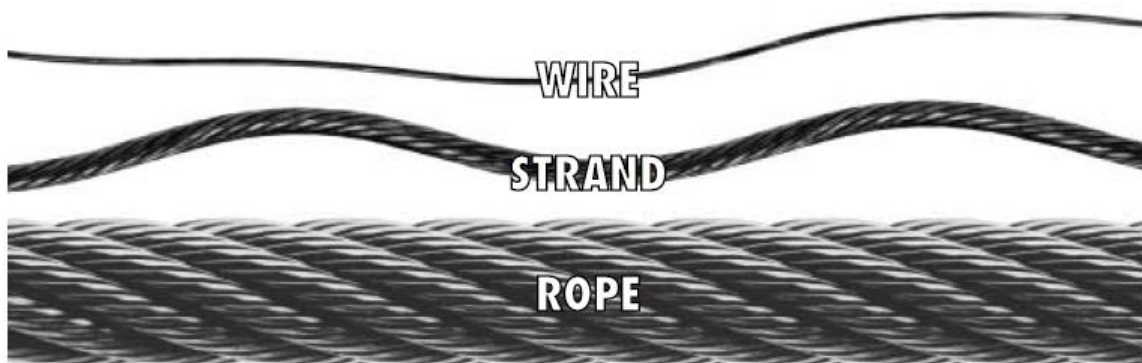

According to DIN EN 12385-2, a "stranded rope is "a construction made of several strands that are helically twisted in one (single layer rope) or several layers (rotation-resistant or parallel lay rope) around an insert or core".

Only wires that meet the requirements of EN 10264-2 are used for the manufacture of our stranded ropes. These wires are first twisted into strands that are finally closed into ropes. During the course of the manufacturing process, lubricant is applied to the strands, core and the rope to prevent internal friction and to protect the rope from corrosion.

3.2.1 Core types

DIN EN 12385-2 defines the core as “an element in the middle of a round rope around which the strands of a stranded rope are helically twisted.”



Wire rope with fibre core



Wire rope with steel core

The different core types according to DIN EN 12385-2

Item or element	Symbol
Single layer rope:	
Fiber core	FC
Natural fiber core	NFC
Synthetic fiber core	SFC
Solid polymer core	SPC
Steel core	WC
Wire strand core	WSC
Independent wire rope core	IWRC
Independent wire rope core with compacted strands	IWRC(K)
Independent wire rope core covered with a polymer	EPIWRC
Parallel-closed rope:	
Parallel wire rope center	PWRC
Parallel wire rope center with compacted strands	PWRC(K)
Rotation-resistant rope:	
Central element	
fiber center	FC
Wire strand center	WSC
Compacted Wire strand center	KWSC

3.2.2 Strand types

DIN EN 12385-2 defines a strand as "an element of the rope that consists of a construction of wires with a suitable form and suitable dimensions that has been helically twisted in one or more layers around a core."

The different strand types according to DIN EN 12385-2

construction type	symbol	examples of strand construction
Single lay		
	No symbol	6 i.e. (1-5) 7 i.e. (1-6)
Parallel lay		
Seale	S	17S i.e. (1-8-8) 19S i.e. (1-9-9)
Warrington	W	19W i.e. (1-6-6+6)
Filler	F	21F i.e. (1-5-5F-10) 25F i.e. (1-6-6F-12) 29F i.e. (1-7-7F-14) 41F i.e. (1-8-8-8F-16)
Combined parallel lay		
	WS	26WS i.e. (1-5-5+5-10) 31WS i.e. (1-6-6+6-12) 36WS i.e. (1-7-7+7-14) 41WS i.e. (1-8-8+8-16) 41WS i.e. (1-6/8-8+8-16) 46WS i.e. (1-9-9+9-18)
Multiple operation lay (round strand)		
Cross lay	M	19M i.e. (1-6/12)
Compound lay*	N	37M i.e. (1-6/12/18) 35NW i.e. (1-6-6+6/16)

* N is additional and precedes the basic type symbol, e.g. Compound Seale is NS and Compound Warrington is NW

3.3 DIRECTION OF LAY OF THE ROPE

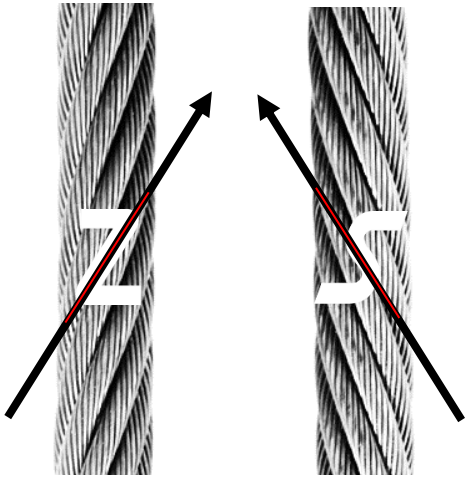

right hand lay rope Z left hand lay rope S

3.4 LAY TYPE OF THE ROPE

3.4.1 Ordinary lay

The wires in the outer strands have an opposite direction of lay than the outer strands in the rope. As a result, the wires practically lie on an axis with the rope itself.

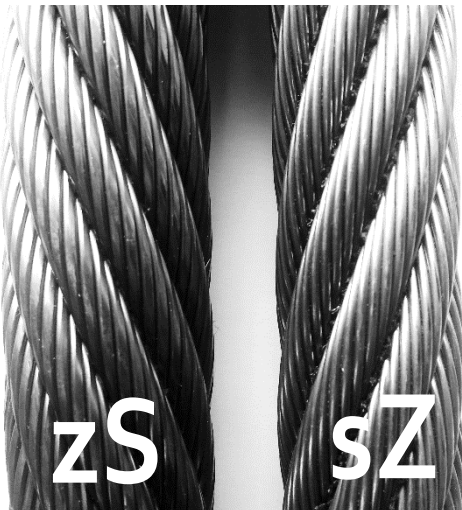

left (zS)

right (sZ)

The first letter refers to the direction of lay of the strand and the second letter refers to the direction of lay of the rope.

3.4.2 Lang lay

The wires in the strands as well as the strands themselves have the same direction of lay. The wires therefore form an angle to the axis of the rope.



left (sS)

right (zZ)

The first letter refers to the direction of lay of the strand and the second letter refers to the direction of lay of the rope.

3.5 CHOOSING THE CORRECT DIRECTION OF LAY

The choice of the correct direction of lay is essential for the proper functioning of a reeving system. A wrong direction of lay leads to torque build-up, spooling problems and structural changes.

ATTENTION

One layer spooling: For drums with one layer, the following applies:

right hand drum – left hand rope

left hand drum – right hand rope

Multiple layer spooling: With multiple layer spooling, the direction of spooling changes from layer to layer. So the direction of lay of the rope would also have to be changed from layer to layer. Here, the direction of lay should be chosen for the layer which is working the most:

right hand layer – left hand rope

left hand layer – right hand rope

Multiple part reeving: In a multiple part reeving system, the influence of the fleet angles between the sheaves is often greater than the influence of the drum. In this case, the direction of lay of the rope should be chosen depending on the direction of the reeving:

right hand reeving – left hand lay rope

left hand reeving – right hand lay rope

And here is how you determine the direction of the winding of the drum or reeving system: Place yourself at the fix point (⊗) of the rope on the drum (at the reeving system) and follow the turns of the rope with your finger.

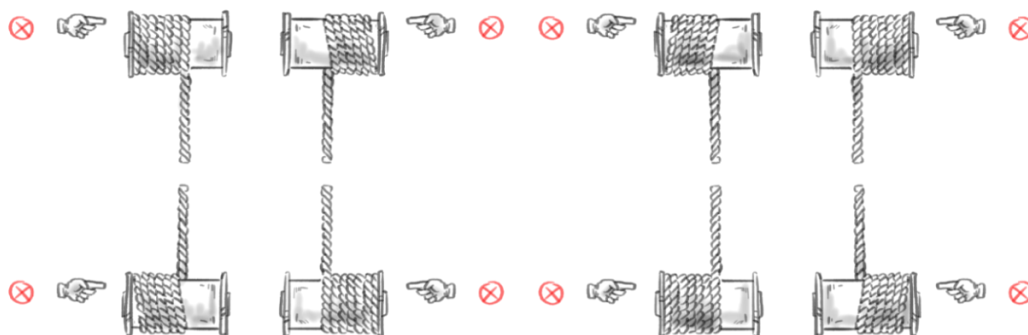

**right hand drum -
left hand lay rope**

If you move your finger clockwise, the drum (reeving system) is right hand, and needs a left hand lay rope.

**left hand drum -
right hand lay rope**

If you move your finger counter-clockwise, the drum (reeving system) is left hand, and needs a right hand lay rope.

3.6 ROTATION-RESISTANT AND NON-ROTATION-RESISTANT ROPES

A helically twisted wire rope tends to “untwist” to reduce its torque under load. The result is that every wire rope - the manufacturer, strength, etc. does not play a role - tends to twist under load.

In a conventional rope that consists of at least 2 strand layers that are twisted around the core in a helical form, the direction of lay of the outer strands matches that of the inner strands. All strands generate a torque under load that is directed in the same, i.e. opening, direction and the rope starts to twist.

A rotation-resistant rope has a steel core that functions as an independent rope and is closed in the opposite direction like the outer strands. Under load, the steel core tries to untwist in one direction while the outer strands try to untwist in the opposite direction. The rope is designed in a way so that the torques of the steel core and the outer strands compensate over a wide load range and thus almost no twisting occurs even at a great lifting height.



Rotation-resistant

The direction of lay of the outer strands is opposite to the direction of lay of the steel core.

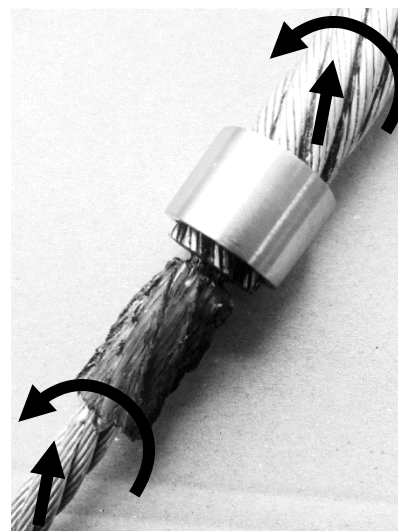

Non-rotation-resistant

The direction of lay of the outer strands and steel core are identical.

3.7 STRENGTH

DIN EN 12385-4 specifies 3 common rope strength classes: 1770, 1960 and 2160.

According to the standard, this involves the performance level of the breaking force that is designated with a number.

Note: This does not necessarily mean that the actual rated strength of the wires in the rope corresponds to this rope strength class.

3.8 SURFACE

According to DIN EN 12385-1, for bright ropes, the replacement of bright wires with galvanised wires is limited to inner wires, core wires, filler wires and wires of the core.

For galvanised stranded ropes, all wires, including the wires of the core, must be galvanised.

A class B coating according to EN 10244-2 must be provided for galvanised wires. The mass of the coating is specified in g/m². For example, it can be determined using the gas volume procedure.

3.9 DIAMETER AND MANUFACTURING TOLERANCE

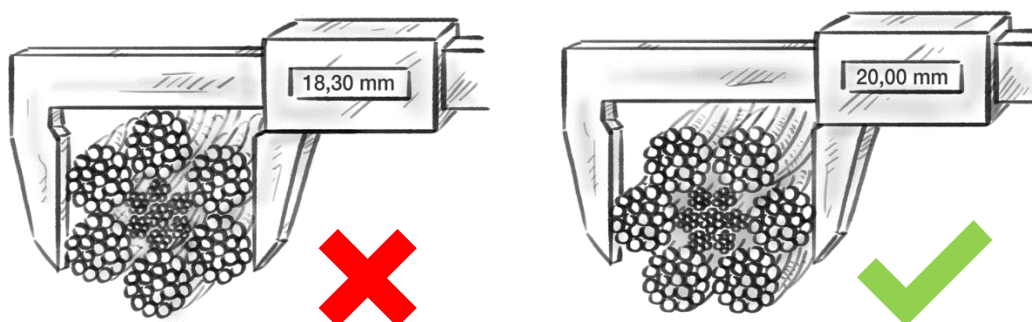

Manufacturing tolerances:

CASAR special wire ropes are manufactured in a tolerance zone between +0% and +4%. Usually, our ropes cover the upper tolerance limit, i.e. between +2% and +4%. CASAR special wire ropes therefore meet the requirements of renowned drum manufacturers and can be used on their products without hesitation. Wire

ropes with limited tolerances and special tolerances can of course also be manufactured on request.

3.10 WIRE ROPE LENGTH

According to DIN EN 12385-1, the actual supplied length of the unloaded rope must correspond to the nominal length, whereby the following limiting dimensions apply:

For a length up to 400 m:	0% to +5%
For a length between 400 and 1000 m:	0 m to +20 m
For a length over 1000 m:	0% to +2%

3.11 THE APPLICATION TEMPERATURE RANGE OF CASAR SPECIAL WIRE ROPES

WARNING



The application temperature range of our CASAR special wire ropes is always specified on the data sheets in the main catalogue. With the specified values for the permitted minimum and maximum temperature, all components used for the relevant rope construction are taken into account. The limitation is usually implemented by the plastic or lubricant used. For example, a maximum value of 115°C applies for the plastic in our ropes with plastic coated steel core.

This rope must also be able to operate in the short-term in a work environment with high surrounding temperatures. It is important that this temperature of 115°C does not extend over the entire rope cross-section. CASAR special wire ropes are therefore used in many steelworks around the world, although the application temperatures briefly reach several hundred degrees Celsius. However, these ropes can only be exposed to these high temperatures very briefly and overheating can be prevented by long cooling times and their favourable thermal conductivity value. The actual rope temperature can be determined with a laser infra-red thermometer, for example.

4. HANDLING WIRE ROPES

4.1 TRANSPORTING SPECIAL WIRE ROPES

ATTENTION

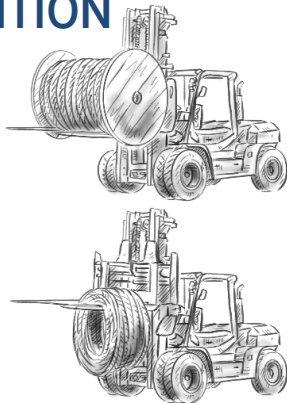

Incorrect handling

Any contact between the steel prongs of the fork lift truck and the rope should be avoided

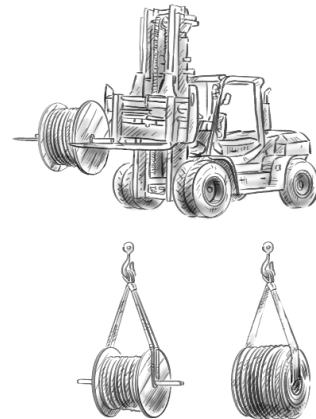

Correct handling

Transporting the ropes with textile slings or tools such as steel rods

4.2 STORING SPECIAL WIRE ROPES

ATTENTION

General rules:

- Keep storage times short
- Steel wire ropes should be stored inside in a clean, dry and cool location
- However, if the ropes have to be stored outside, the rope must be protected from heat, rain and dust
- Ropes should not stand on the ground without protection - store on reel
- Storage outside requires a special breathable protective film that protects the rope from rainwater but also allows condensation to escape

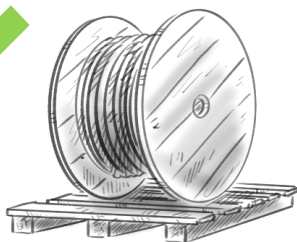

5. INSTALLATION OF STEEL WIRE ROPES

Objective: The rope should be introduced into the reeving system of the application without tension, twisting or damage.

5.1 INCORRECT UNWINDING

ATTENTION

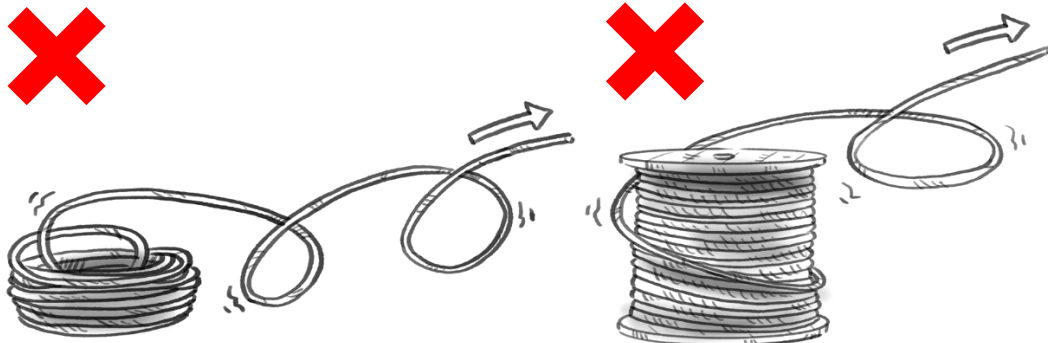

Removal from coil from the side

Removal from reel from the side

Incorrect: The work operation shown creates a torsion for each winding in the rope that can result in loops. If this rope is then pulled tight, it causes irreparable kinks. The rope must be discarded.

5.2 CORRECTLY UNWINDING A STEEL WIRE ROPE FROM THE COIL



Unwinding with a turntable

Rolling out on the ground

Correct: The rope should be rolled out on a turntable or like a tyre on the ground. However, when rolling out, make sure that the ground is clean so that the rope lubricant cannot pick up dirt and form an abrasive paste.

5.3 CORRECTLY UNWINDING A STEEL WIRE ROPE FROM THE REEL

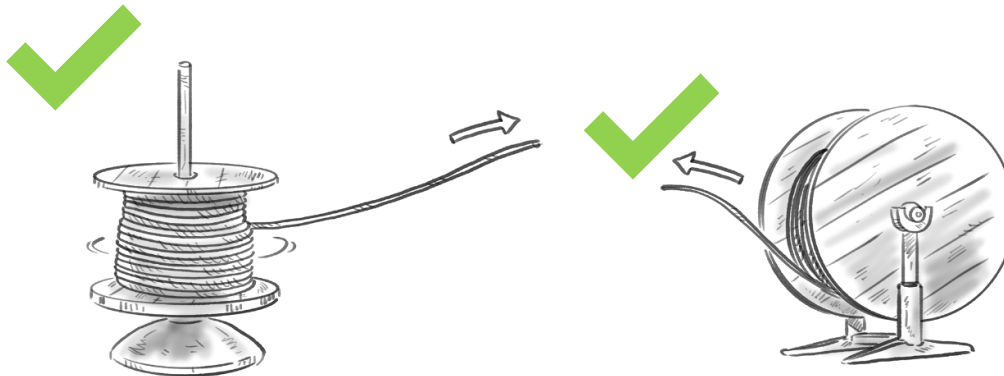

Unwinding with a turntable

Unwinding with a frame

A turntable can also be used when unwinding the rope from a reel. However, the use of a frame or winding block to neatly unwind the rope is recommended for large reels and thick ropes.

5.4 WINDING THE ROPE FROM A REEL TO A DRUM

CAUTION



During the manufacturing process, every steel wire rope receives its preferred bending direction. Make certain that it bends in the same direction when it is wound from the reel onto the drum. For this reason, the rope winding on the drum and the rope unwinding from the reel must always hold the same position, i.e. bottom to bottom or top to top. If the rope is pulled diagonally, i.e. winding in the opposite direction to the preferred bending direction, it will either try to twist between reel and drum or it will later try to regain its preferred position when in practical service. In both cases, structural changes to the rope may occur.

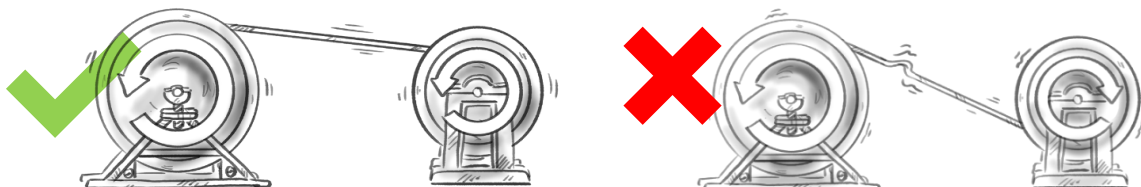

Correct winding in bending direction

Incorrect winding opposite to bending direction

5.5 THE FLEET ANGLE

The fleet angle (β) describes the lateral deflection of a rope on the drum or, in the reeving system, the deflection that a rope experiences, which spools from a fixed sheave from one edge of a drum to the other. Here it must be taken into account that the fleet angle for a typical arrangement with the sheave central to the drum naturally has its maximum at the drum edges. In addition the rope grooves on the drum itself also describe an angle, the so-called pitch angle (α), that must be subtracted from the fleet angle (β) or added to it.

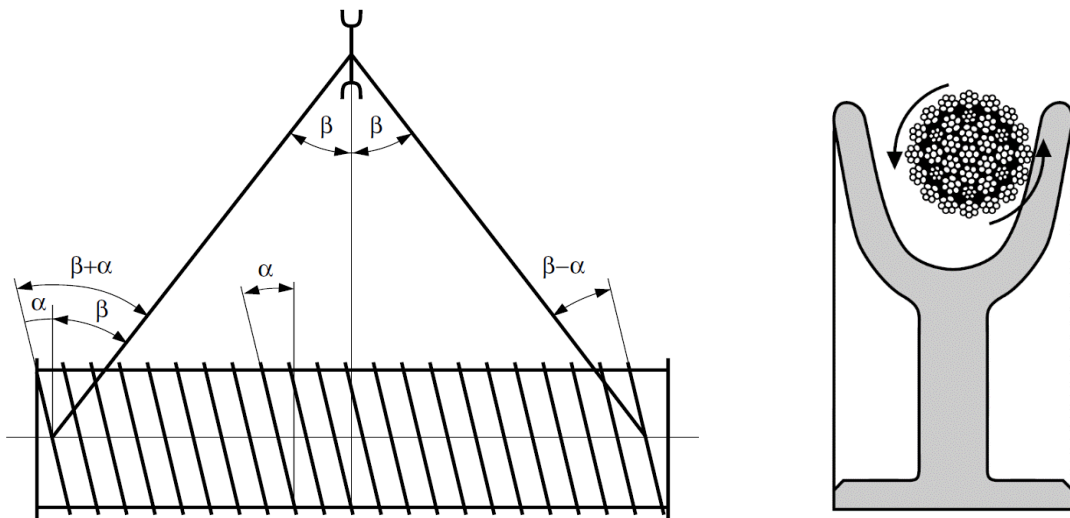

CAUTION



Generally the rope fleet angle causes the rope to not wind to its lowest point but instead the sheave first touches an edge and then rolls into the bottom of the groove. This so-called “forced torsion of the rope” increases with the fleet angle. The authoritative ISO standard 16625 limits the fleet angle to 4° for non-rotation-resistant ropes and 2° for rotation-resistant and low rotation ropes. This narrow restriction for low rotation and rotation-resistant ropes results from the fact that ropes with steel cores closed in the opposite direction respond more sensitively to forced torsion than conventional ones.

Lateral deflection can of course arise during rope installation. Here, the specified maximum fleet angle from ISO 16625 must also be complied with to prevent twisting developing during rope installation. The fleet angle can be minimised by establishing as large a distance as possible between the reel and drum or head pulley sheave.

5.6 THE GROOVES OF DRUMS AND SHEAVES

Naturally, each component of a crane that comes into direct contact with the rope has an effect on the service life. This also includes the grooves of the sheaves and the drum whose quality and dimensional accuracy have a significant influence on the service life of the rope. Here, the grooves should have a diameter that is slightly larger than the effective diameter of the rope. ISO 16625 prescribes that the diameter of the grooves must be a minimum of 5% and a maximum of 10% more than the rope diameter. As an optimum value, the standard specifies a groove diameter of 7.5% more than the rope diameter.

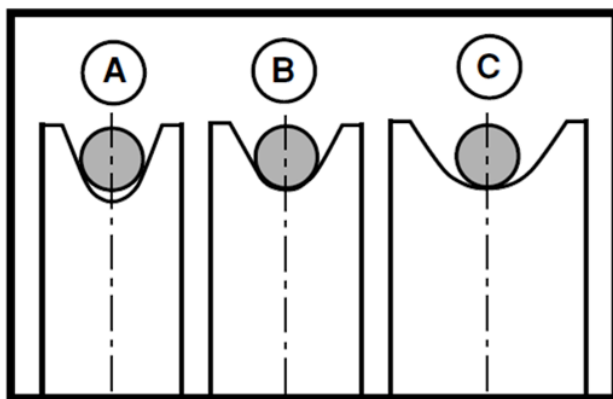

CAUTION



If the diameter of the sheave is too small for the rope (Fig. A), the rope is compromised when winding on the sheave or drum. This can lead to wire breaks in the inside of the rope caused by so-called arch pressure. An additional effect is excessive length of the outer strands in respect of the reduced rope diameter. This excessive strand length is typically shifted to a point and results in strand loosening or even birdcage deformation (see figure "Birdcage deformation" in section 7.5).

A rope groove that is too large results in a greater surface pressure of the rope in the bottom of the groove as the support at the edges is missing and therefore the contact area is reduced (Fig. C). The increased pressure in the bottom of the groove and the additional tensions due to the intensified rope deformation (ovalisation of the rope) lead to a reduction of the service life.

In general, falling below 5% has significantly more serious consequences for the service life of the rope than exceeding 10%.

To determine the diameter of the rope grooves of sheaves and drums, so-called groove gauges are used. These are pressed into the rope groove and should be

well positioned over broad sections of the circumference. The rope groove is then OK.

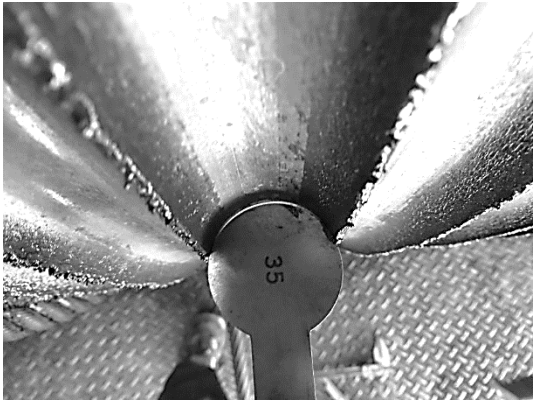

If the groove gauge only lies at the edge, the groove is too narrow for the gauge.

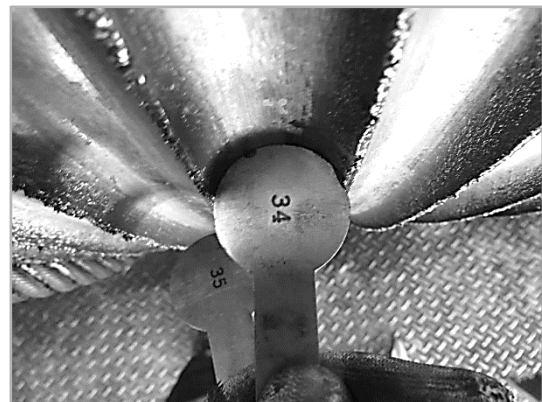

If the groove gauge lies above the majority of the circumference, the groove dimensions are OK.

The groove profile should also be circular and smooth and should not feature any furrows. The depth of the groove (h) should at least correspond to 1.5x the rope inner diameter. The opening angle (ω) should be between 45° and 60° .

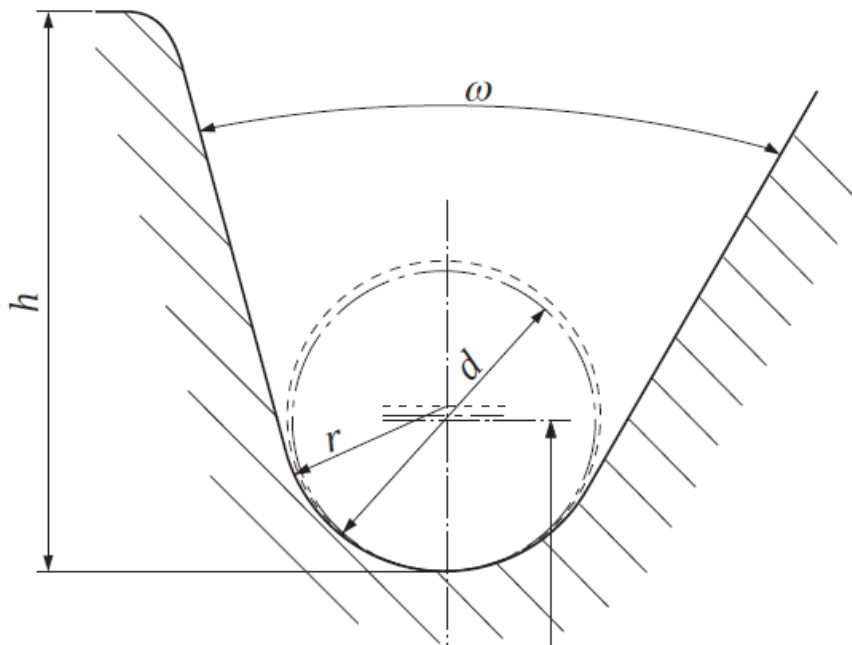

If a rope groove does not have a smooth profile, but instead has so-called negative imprints, the relevant drum or sheave must be reworked or replaced during the next rope replacement.

5.7 INSTALLING THE NEW ROPE

CAUTION



Usually the new wire rope is pulled up by a thinner rope or the old rope. In both cases, a safe connection between these ropes must be ensured.

When pulling up with the thinner rope, it must be ensured that it cannot rotate. Ideally, rotation-resistant rope designs or 3-strand or 4-strand ropes are used. However, if conventional wire ropes are used, you must at least make sure that they have the same direction of lay as the rope to be installed.

If the new rope is pulled in with the help of the used one, the transfer of the twist of the old rope, built up in the reeving system, into the new rope must be prevented. Welding the ends to each other is strongly discouraged. In addition, this type of connection can break due to the long length of the rigid connection zone as a result of the bending load when running over sheaves. Here, it is recommended to connect the wire ropes through two mounting lugs welded at the ends (rings or chain links), also called mounting eyes, which are connected using strands or thin ropes. This connection is flexible and prevents the transfer of twist. The number of turns after installation is also used as an indicator for the intensity of the twist on the rope.

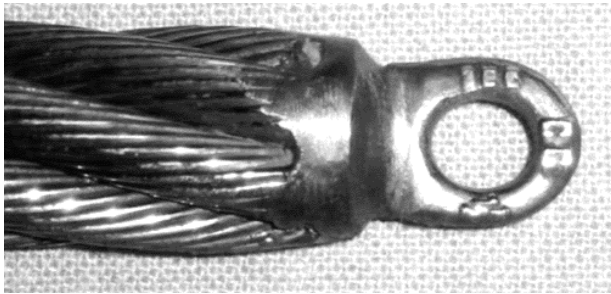

However, the constantly increasing performance of cranes and winches throughout the world lead to increasing requirements for the ropes as well as the accessories. That is why CASAR offers a special solution for rope installation - the heavy-load installation eye.

Heavy-load installation eye

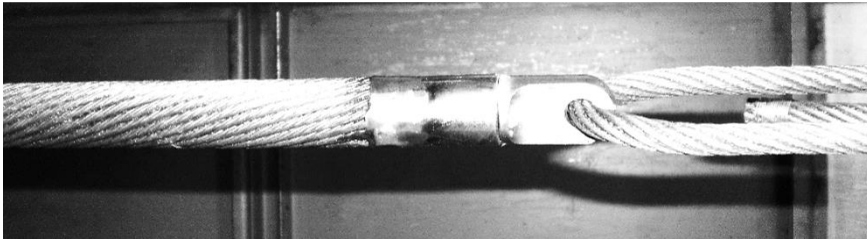

There are two versions of the heavy-load installation eye (patent pending). The first one is completely welded, which can also be achieved with protective gas on the construction site. It must be noted that the welding is not easy and must be carried out by a specialist. The strong weld seams guarantee a secure connection.

The second version is a combination of a pressed-in sleeve and a welded installation eye. To attach the installation eye, first the outer strands of the rope must be stripped off to be able to push the sleeve on the steel core. The sleeve is then pressed on the steel core and the gap between the sleeve and outer strands are welded. This mixture of welding and pressing provides additional safety, as the connection area between rope and installation eye is very large and there are two load paths independent of each other.

At first glance, an installation eye does not seem to be spectacular, as its service is ended when rope installation is completed and it is not significant for the ongoing operation. However, every expert knows the errors that can be made during installation and the dramatic impact this can have on the rope. With our heavy load installation eye, we have succeeded in developing a strong and reliable installation aid for our partners and customers. This is particularly important for installation in mines, on offshore platforms and large cranes where ropes with large piece weights must be installed. In addition, we recommend installing this rope under a certain preload, which additionally increases the load on the installation eye.

Both versions of the heavy load installation eye achieve extraordinarily high breaking forces. This minimum breaking force can be further increased by small changes to the design. Even special designs that meet special requirements with regard to freedom of movement, boreholes, etc. can be realised at any time without difficulty.

We can attach heavy load installation eyes to any wire rope that we produce.

Even so-called Chinese fingers can be used for installation. This braid of strands is pushed over the rope end, draws tight under load and holds the rope ends by means of friction.



Both ends can also be connected with strands or thin ropes, which then inhibit the transfer of twist during installation.



5.8 THE PRELOAD

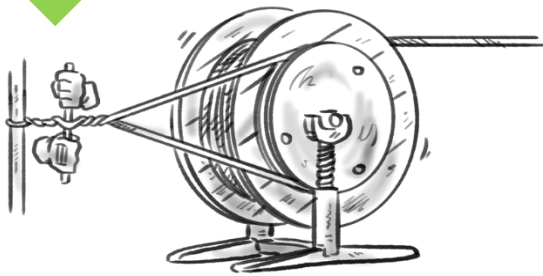

Application of the preload using a braking disc at the reel



Application of the preload by braking the reel flange

To achieve perfect multiple layer spooling of the rope on the drum, it is very important - particularly with the so-called Lebus spooling - to apply a tensioning load to the wire ropes during the installation.

If the first layers are too loose, the top layers might be wedged into the bottom layers under load. This could seriously damage the rope. The unwinding rope might even be clamped, so that the direction of spooling could suddenly be reversed during the course of unwinding. The result could be the abrupt lifting of the load that was actually travelling downwards.

The tensioning load should range from 1% to 2% of the minimum breaking load of the wire ropes.

In many cases, it might suffice to wind the rope quite normally in order to unwind it and then rewind it with the help of an outer load. In other cases, however, e.g. when erecting a tower crane that has not yet reached its maximum height, the procedure mentioned above is not possible. In these cases, the tensioning load must already be applied when installing the rope. Ample rope tension can be provided by a simple plank bearing against the reel flanges or by a braking disk attached to the reel.

ATTENTION

Under no circumstances should one attempt to generate the tensioning load by jamming the rope, for instance between two boards.

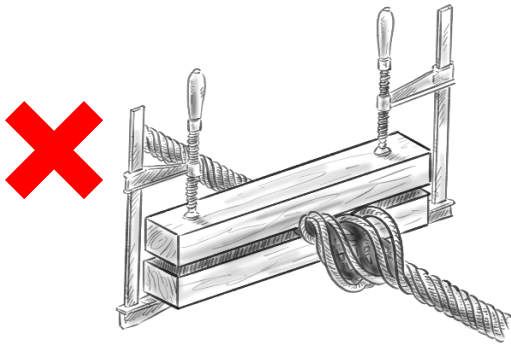

Incorrect procedure: Clamping the wire rope can cause a structural change or even birdcage formation.

5.9 "BREAKING IN" THE STEEL WIRE ROPE

After the rope has been installed and before it is going to do its actual job, several run-throughs of the normal operational circle should be carried out under light load. The new rope should be "broken in", so that the component parts can settle and adjust themselves to the actual operating conditions. Unfortunately, it is only too often the exact opposite of this recommendation that occurs in practice: quite frequently after installing the rope, overload tests are carried out with loads beyond the safe working load of the system.

5.10 CUTTING STEEL WIRE ROPES

CAUTION



If the intention is to cut or shorten a wire rope, the wire ropes must always be tied up next to the cut points to prevent the rope ends jumping out or a change to the rope and strand length. This is particularly important when cutting rotation resistant ropes where the strands may have been deliberately non-preformed as part of the manufacturing specification.

Each side of the cut must be tied up with steel wire. Insulating tape and adhesive tape do not prevent effective structural changes.

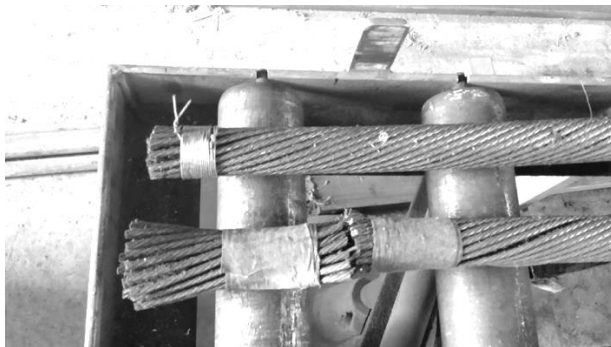

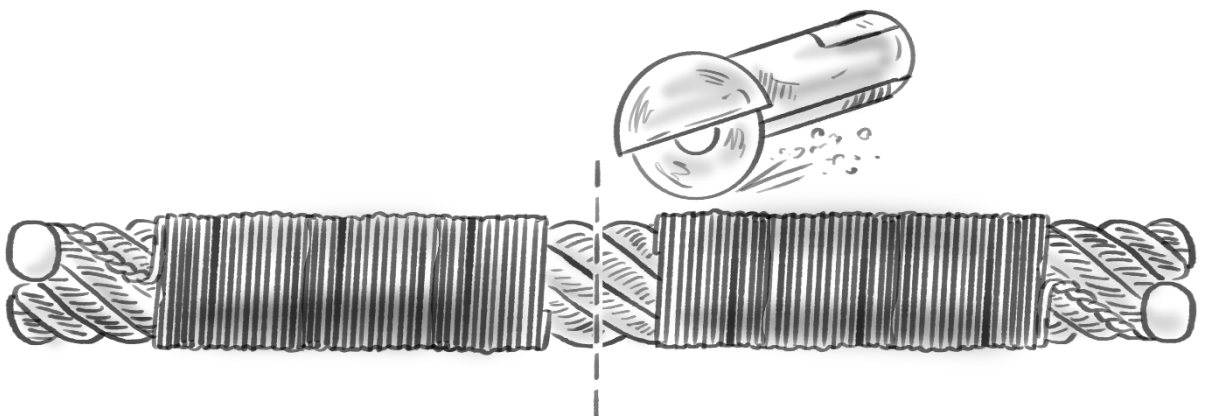
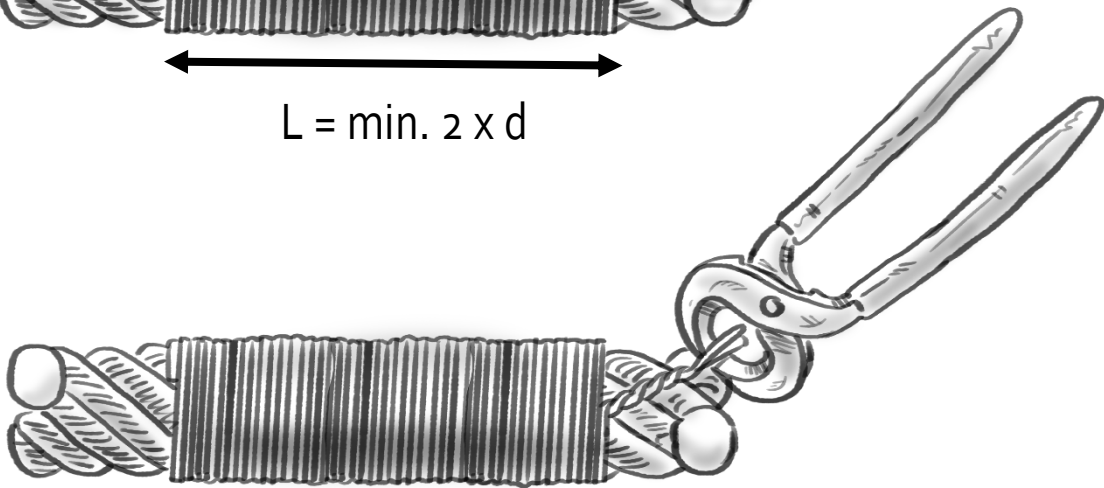
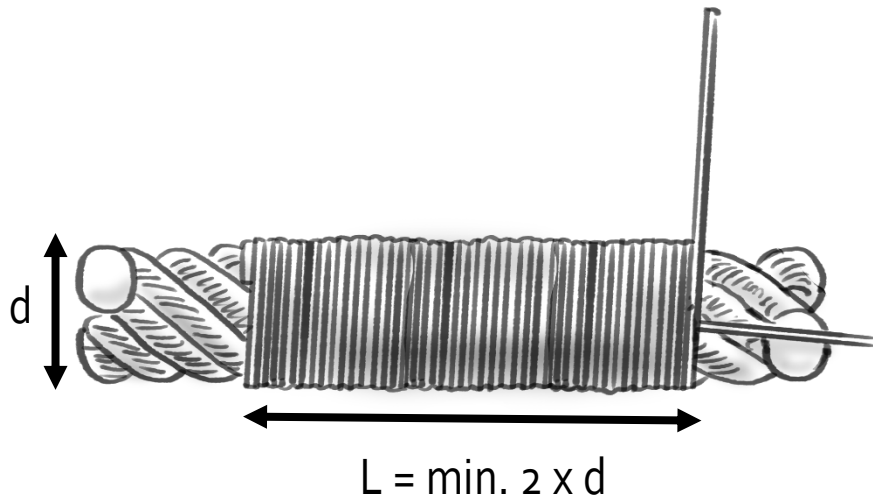
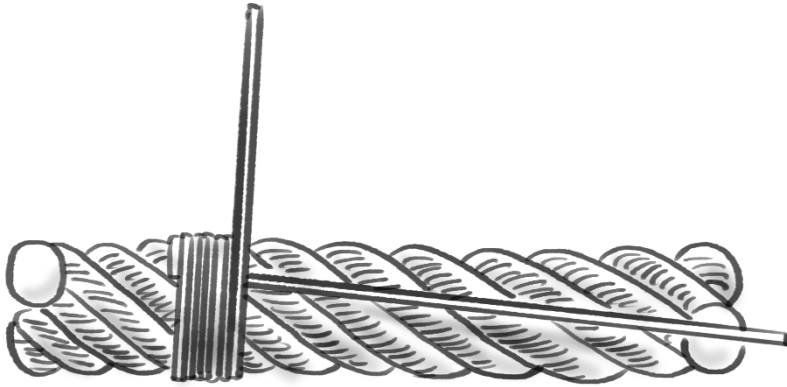

6. MAINTAINING STEEL WIRE ROPES

6.1 RELUBRICATING STEEL WIRE ROPES

ATTENTION



During the production process, the rope receives intensive lubrication. This provides the rope with ample protection against corrosion and is meant to reduce the friction between the elements which make up the rope as well as the friction between rope and sheaves or drums. Generally, this lubrication does not last over the full service life of a wire rope. For this reason, German standard DIN ISO 4309 recommends relubricating a wire rope before any signs of dryness and corrosion appear. Special attention should be given to the rope zones that run over sheaves, onto the drum or from it, as well as sections that run over compensating sheaves.

When choosing the relubricant, it must be ensured that it is in accordance with the recommendations of the rope manufacturer. We can give you further details and a recommendation for this.

There are several techniques for lubricant application:

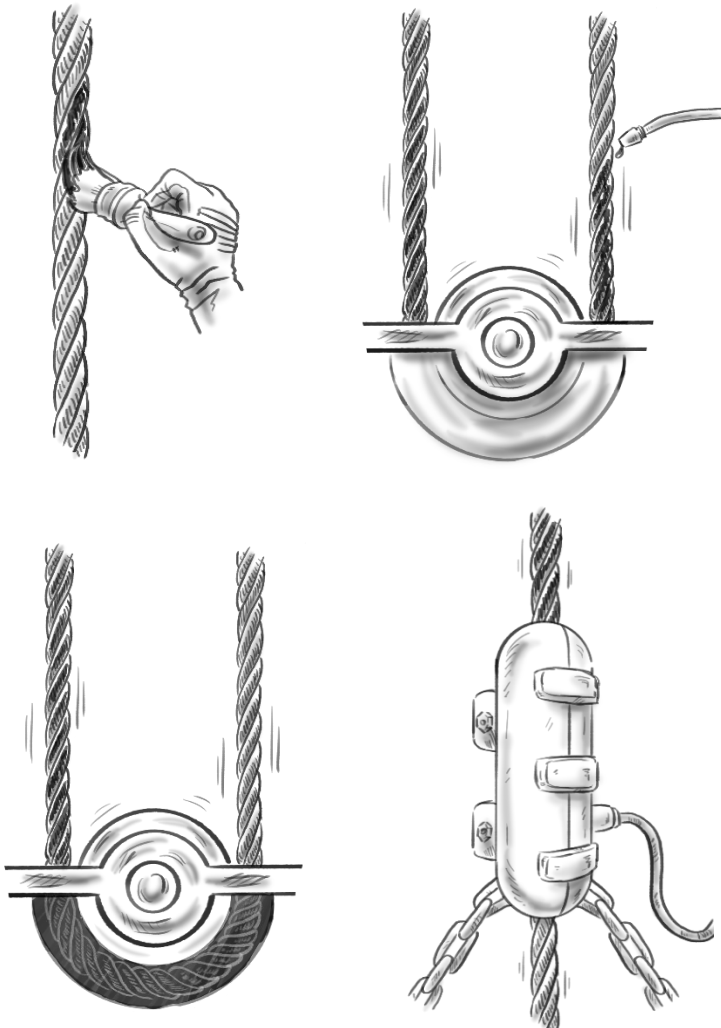

The most common ones at present are painting or swabbing. Quite often, the lubricant is applied at a sheave.

Sometimes a continuous drip method is used. If only a little lubricant is required, spray nozzles can be applied.

Various other systems allow the application of a continuous lubricant bath.

Maximum penetration of the lubricant into the gaps of the rope can only be guaranteed, if high pressure lubrication is applied with the help of a pressure lubricator. With this method, the two halves of a sleeve, which is equipped with rubber sealings, are clamped round the rope and screwed together. While the rope runs through the lubricator, the lubricant is pressed into the sleeve at a pressure up to about 30 bars.

IMPORTANT

All different methods of relubrication of steel wire ropes should be carried out regularly from the beginning of the service life of the rope and not only after the first damage has been ascertained.

6.2 CLEANING WIRE ROPES



If a wire rope is very dirty, it should be cleaned externally from time to time. This applies particularly to ropes operating in extremely abrasive conditions and to those that take up chemicals.



Effective cleaning without proper tools is quite a laborious job. Appliances with rotating brushes and an air blast drying stem to follow or a so-called "rope porcupine", a rotating sleeve equipped with brushes, which is drawn along the steel wire rope, are recommended.

6.3 REMOVING BROKEN WIRES

ATTENTION



If, during an inspection, ends of broken wires are detected which might cross adjacent wires and destroy them when running over sheaves, these broken wire ends must be removed.



Under no circumstances should the broken wire ends be pinched off with a pair of nippers. The best method is to move the wire ends backwards and forwards until they break deep in the valley between two outer strands.

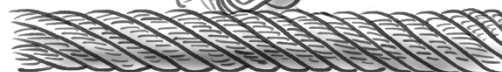
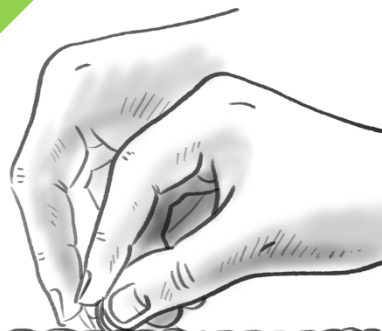
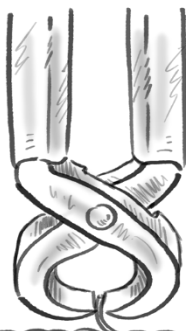

7. DISCARD CRITERIA ACCORDING TO DIN ISO 4309

7.1 VISIBLE WIRE BREAKS

CAUTION



The maximum permitted number of wire breaks complies with the so-called "rope category number" (RCN) or the total number of load-bearing wires in the outer strand layer of the rope. The RCN number for each CASAR rope of each diameter is listed in the CASAR rope catalogue. Either a section that is 6x the nominal rope diameter or 30x the nominal rope diameter is used here as the reference length.

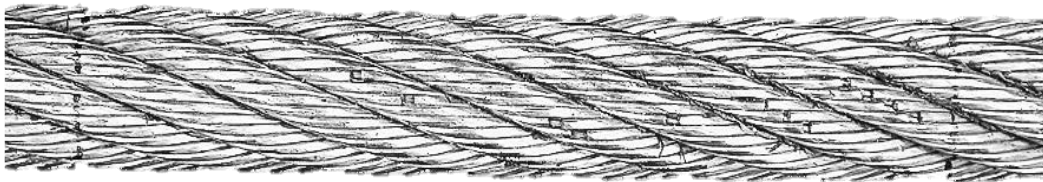

Single layer and parallel stranded ropes

Number of visible wire breaks that indicate that the discard state has been reached or exceeded for single layer and parallel stranded ropes.

NOTE: Ropes with outer strands in the Seale design for which the number of wires per strand is 19 or less (e.g. 6 × 19 Seale) are classified in this table two lines above the line in which the design would normally be due to the number of load-bearing wires in the outer strands.

		Number of visible broken outer wires ²⁾					
		Rope working (single-layer drum)				Rope spooling (multi-layer drum) ³⁾	
		Sections of rop working in steel sheaves and/or spooling on a single-layer drum				Sections of rope spooling on a multi-layer drum	
		Classes M1 to M4 or class unknown ⁴⁾				All classes	
		Ordinary lay (sZ, zS)		Lang lay (sS, zZ)		Ordinary and Lang lay	
RCN	Number of load-bearing wires in the outer strands of the rope ¹⁾ n	Over a length of 6d ⁵⁾	Over a length of 30d ⁵⁾	Over a length of 6d ⁵⁾	Over a length of 30d ⁵⁾	Over a length of 6d ⁵⁾	Over a length of 30d ⁵⁾
01	$n \leq 50$	2	4	1	2	4	8
02	$51 \leq n \leq 75$	3	6	2	3	6	12
03	$76 \leq n \leq 100$	4	8	2	4	8	16
04	$101 \leq n \leq 120$	5	10	2	5	10	20
05	$121 \leq n \leq 140$	6	11	3	6	12	22
06	$141 \leq n \leq 160$	6	13	3	6	12	26
07	$161 \leq n \leq 180$	7	14	4	7	14	28
08	$181 \leq n \leq 200$	8	16	4	8	16	32
09	$201 \leq n \leq 220$	9	18	4	9	18	36
10	$221 \leq n \leq 240$	10	19	5	10	20	38
11	$241 \leq n \leq 260$	10	21	5	10	20	42
12	$261 \leq n \leq 280$	11	22	6	11	22	44
13	$281 \leq n \leq 300$	12	24	6	12	24	48
	$n > 300$	$0,04 \times n$	$0,08 \times n$	$0,02 \times n$	$0,04 \times n$	$0,08 \times n$	$0,16 \times n$

- 1) For the purposes of this international standard, filler wires are not considered as load-bearing wires and are not included in the value for n.
- 2) A broken wire has two ends (counted as one wire).
- 3) The values apply for damage in the crossover areas and overlays of windings due to deflection angles (not for rope sections that only run on sheaves and do not reel on the drum).
- 4) For ropes on motors of groups M5 to M8, double the listed number of wire breaks can be applied.
- 5) d = rope nominal diameter.

The classes M1 to M4 are the same as the motor groups 1E_m to 1A_m

The classes M5 to M8 are the same as the motor groups 2_m to 5_m

Please also observe the standards specific to the country and application.

Rotation-resistant rope

Number of visible wire breaks that indicate withdrawal from service has been reached or exceeded for low rotation ropes.

NOTE: Ropes with outer strands in the Seale design for which the number of wires in each strand is 19 or less (e.g. 18 x 19 Seale - WSC) are classified in this table two lines above the line in which the design would normally be due to the number of load-bearing wires in the outer strands.

RCN	Number of outer strands or number of load-bearing wires in the outer strands of the rope ¹⁾ n	Number of visible broken outer wires ²⁾			
		Rope working on a single-layer drum		Rope spooling on a multi-layer drum ³⁾	
		Sections of rop working in steel sheaves and/or spooling on a single-layer drum		Sections of rope spooling on a multi-layer drum	
		Over a length of 6d ⁴⁾	Over a length of 30d ⁴⁾	Over a length of 6d ⁴⁾	Over a length of 30d ⁴⁾
21	4 strands n ≤ 100	2	4	2	4
22	3 or 4 strands n ≥ 100	2	4	4	8
11 or more outer strands					
23-1	71 ≤ n ≤ 100	2	4	4	8
23-2	101 ≤ n ≤ 120	3	5	5	10
23-3	121 ≤ n ≤ 140	3	5	6	11
24	141 ≤ n ≤ 160	3	6	6	13
25	161 ≤ n ≤ 180	4	7	7	14
26	181 ≤ n ≤ 200	4	8	8	16
27	201 ≤ n ≤ 220	4	9	9	18
28	221 ≤ n ≤ 240	5	10	10	19
29	241 ≤ n ≤ 260	5	10	10	21
30	261 ≤ n ≤ 280	6	11	11	22
31	281 ≤ n ≤ 300	6	12	12	24
	n > 300	6	12	12	24

- 1) For the purposes of this international standard, filler wires are not considered as load-bearing wires and are not included in the value for n.
- 2) A broken wire has two ends.
- 3) The values apply for damage in the crossover areas and overlays of windings due to deflection angles (not for rope sections that only run on sheaves and do not reel on the drum).
- 4) d = rope nominal diameter.

Please also observe the standards specific to the country and application.

7.2 DIAMETER REDUCTION

7.2.1 Uniform reduction along the rope

Rope type	Uniform decrease in diameter	Severity rating	
		Description	%
single-layer rope with fiber core	$x < 6 \%$	—	0
	$6 \% \leq x < 7 \%$	Slight	20
	$7 \% \leq x < 8 \%$	Medium	40
	$8 \% \leq x < 9 \%$	High	60
	$9 \% \leq x < 10 \%$	Very high	80
	$x \geq 10 \%$	Discard	100
single-layer rope with steel core or parallel-closed rope	$x < 3,5 \%$	—	0
	$3,5 \% \leq x < 4,5 \%$	Slight	20
	$4,5 \% \leq x < 5,5 \%$	Medium	40
	$5,5 \% \leq x < 6,5 \%$	High	60
	$6,5 \% \leq x < 7,5 \%$	Very high	80
	$x \geq 7,5 \%$	Discard	100
rotation-resistant rope	$x < 1\%$	—	0
	$1 \% \leq x < 2 \%$	Slight	20
	$2 \% \leq x < 3 \%$	Medium	40
	$3 \% \leq x < 4 \%$	High	60
	$4 \% \leq x < 5 \%$	Very high	80
	$x > 5 \%$	Discard	100

Calculation method to determine the extent of the diameter reduction:

$$\frac{d_{\text{ref}} - d_m}{d_{\text{nom}}} \times 100\%$$

d_{ref} = reference diameter, measured diameter of a rope section that is not bent over sheaves that was immediately measured after commissioning the rope

d_m = measured diameter

d_{nom} = nominal rope diameter

7.2.2 Local reduction

If there is an apparent local diameter reduction, due to failure of a rope core, for example, discard the rope.

7.3 STRAND BREAK

Discard the rope immediately, if a complete strand is broken.

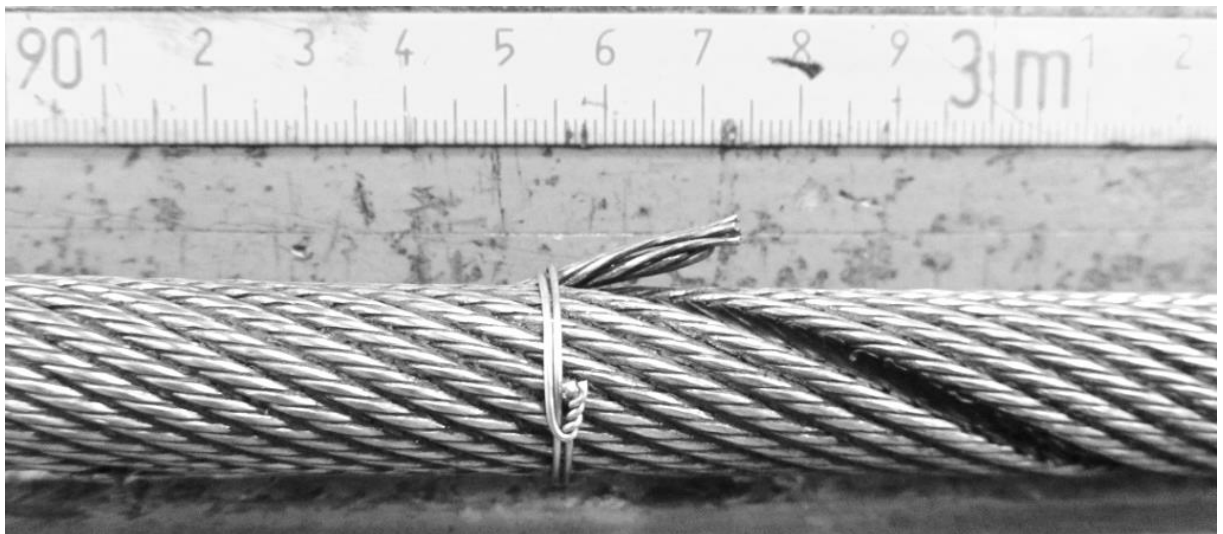

7.4 CORROSION

type of corrosion	condition	severity rating
External corrosion^a	Signs of surface oxidation but can be wiped clean wire surface rough to touch wire surface heavily pitted and slack wires ^b	Superficial – 0 % High – 60 % ^c Discard – 100 %
Internal corrosion^d	Obvious visible signs of internal corrosion – i.e. corrosion debris exuding from the valleys between the outer strands ^e	Discard – 100 % or if deemed practicable by the competent person, internal examination in accordance with the procedure described in Annex C
fretting corrosion	The process of fretting involves the removal of fine particles of steel from the wires due to dry wires and strands constantly rubbing together and then oxidizing and creating internal corrosion debris which manifests itself as dry powder, similar to a red rouge.	evidence of such a characteristic should be further investigated and if there is any doubt about its severity, the rope should be discarded (100%)

- a) Examples of this are shown in figures B.11 and B.12. An example of the progress of external corrosion in a rope is shown in Annex H.
- b) For each other intermediate state, an assessment with regard to the degree of severity classification must be performed (i.e. proportion of the combined effect).
- c) The wire surface can also feel raw due to oxidation of the galvanised wires; however the overall condition may not be so serious as for ungalvanised wires. In such cases, the tester can consider the application of a lower proportion of the combined effect compared with the classification specified in this table.
- d) An example of this is given in figure B.19.
- e) The assessment of corrosion in the inside of the rope is subjective; if the severity of corrosion in the inside of the rope is not certain, the rope should be discarded.

7.5 DEFORMATION AND OTHER DAMAGE

Every visible deviation of the rope from its normal shape is classified as deformation. DIN ISO 4309 lists the following types of deformations and damage:

- Corkscrew-type deformations
- Birdcage formation
- Protruding or deformed core or strand
- Looping
- Local increase in rope diameter
- Flattening
- Kinks or tightened rope sling
- Kinks in the rope
- Damage due to heat exposure or light arcs

If this type of damage occurs, examine the damaged area intensively and make a decision about operational readiness with aid of the standard.



Corkscrew-type deformations

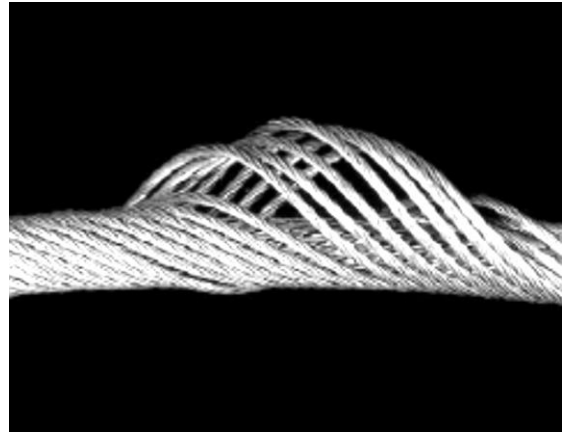

Birdcage formation

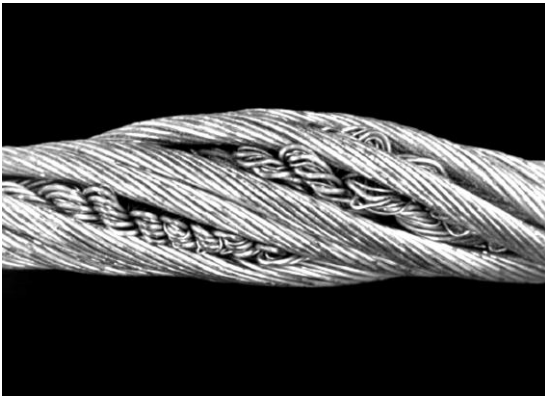

Protruding or deformed core or strand

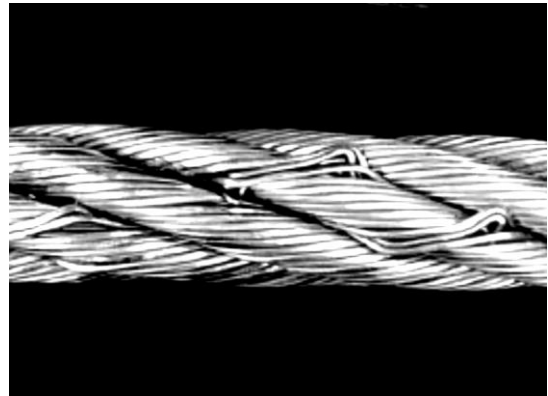

Looping



Flattening



Kinks or tightened rope sling



Kinks in the rope



Damage due to heat exposure or light arcs



Worn-out or elongated wires of a casting crane rope

BIBLIOGRAPHY/DIRECTORY OF APPLICABLE STANDARDS

EC Directive on Machinery 2006/42/EC / Annex IIB

ISO 4309:2010-08 Cranes – Wire ropes – Maintenance and servicing, inspection and storage

ISO 16625:2013 Cranes and hoists – Selection of wire ropes, drums and sheaves

EN 12385-1: 2002+A1: 2008 Steel wire ropes - Safety - Part 1: General requirements

EN 12385-2: 2002+A1: 2008 Steel wire ropes - Safety - Part 2: Terms, designation and classification

EN 12385-3: 2004+A1: 2008 Steel wire ropes - Safety - Part 3: Information for use and maintenance

EN 12385-4: 2002+A1: 2008 Steel wire ropes - Safety - Part 4: Stranded ropes for general lifting purposes

EN 12385-10: 2003+A1: 2008 Steel wire ropes - Safety - Part 10: Spiral ropes for general structural applications

EN 13411-4: 2011-06 End connections for steel wire ropes - Safety - Part 4: Cast with metal and plastic

EN10264-1: 2012-3 Steel wire and wire products - Steel wire for ropes - Part 1: General requirements

EN10264-2: 2012-3 Steel wire and wire products - Steel wire for ropes - Part 2: Cold-drawn non-alloy steel wire for ropes for general applications.